



R4 Rotary Latch

Micro · Concealed · Single and two stage

- Ideal for space limited applications
- Compatible with wide array of actuators
- Integrated bumper for anti-vibration feature

Material and Finish

Steel, zinc plated

Performance Details

Average ultimate load:
2600 N (590 lbf)

Installation Notes

See page 259

Accessories

Cables and retainer clips
see pages 272-275

Notes

Electromechanical rotary latch
available see page 23

Single Stage - Hand Actuation, Integrated Bumper

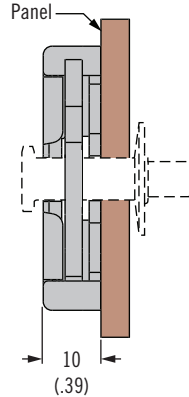
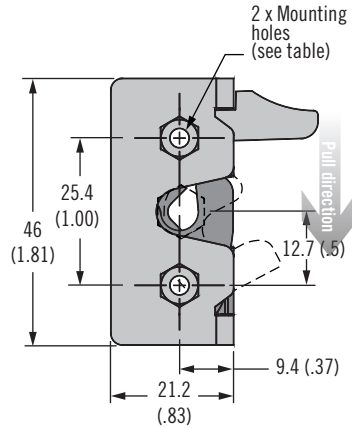

Part Number	
Striker bolt	R4-90-0521-10

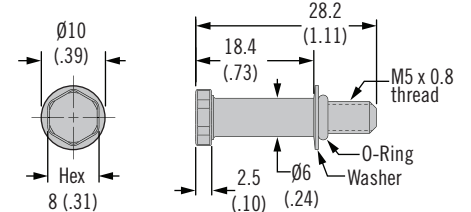

Part Number	
Molded striker	R4-0-61336

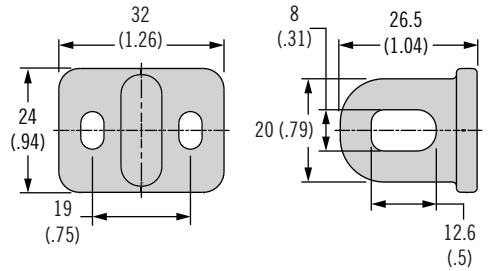

Two Stage - Bottom, Integrated Bumper

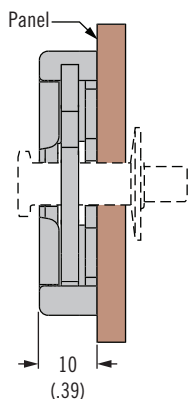
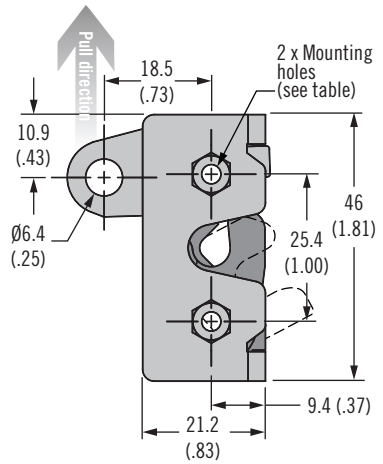

Part Number	
Wire form striker	R4-0-61352

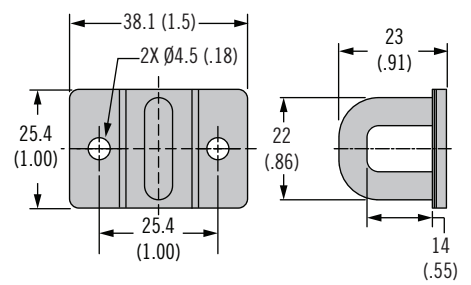

Part Number Selection

- S Stage & Actuation**
- 2 Single stage
 - 4 Two stage

- L Lever Type**
- 4 Hand Actuation
 - 5 Bottom

R4 - 05 - S I - L 05 - M

- I Mounting Style**
- 0 4.5 (.177) thru
 - 1 8-32 thread
 - 2 M4 x 0.7 thread

- M Material**
- 10 Steel

Other options available. For complete details on variety, part numbers, installation and specification, go to



www.southco.com/R4

Dimensions in millimeters (inch) unless otherwise stated

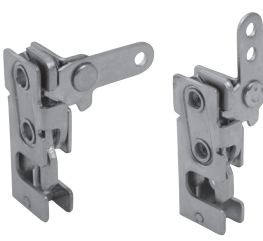

R4 Rotary Latch

Mini · Concealed · Single and two stage

- Single or multi-point latch capability
- Compatible with wide array of actuators
- EN 45545-3 E60 Compliant (Standard version only)
- Integrated bumper version for anti-vibration feature

Material and Finish

Steel, zinc plated or 304 stainless steel, passivated

Performance Details

Average ultimate load: 4600 N (1100 lbf)

Installation Notes

See page 259

Accessories

Striker bolts for standard version and integrated bumper version are different. See page 259 for both versions.

Cables and retainer clips see pages 272-275

Notes

Electromechanical rotary latch available see page 23

Part Number Selection

Single Stage - Perpendicular (left hand actuation shown)

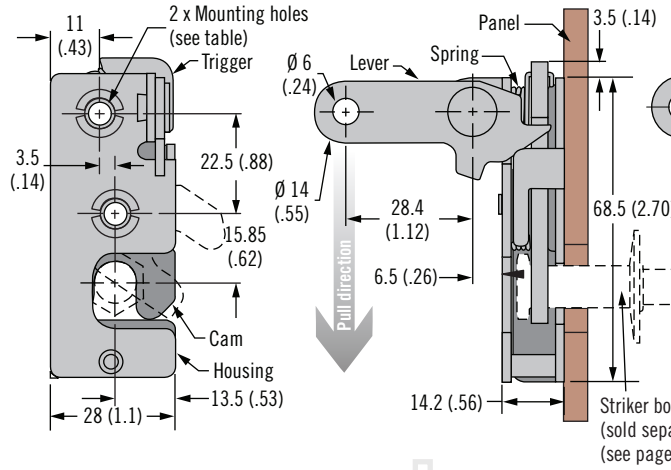

Integrated Bumper Version (dimensions same as standard version except as shown)

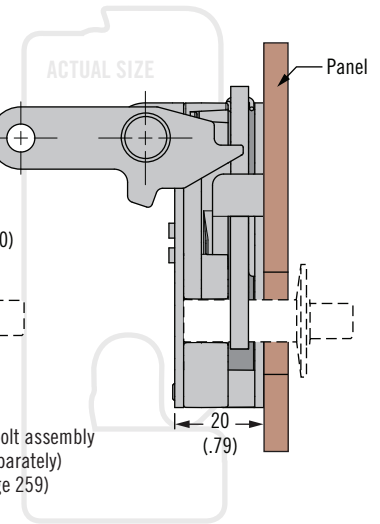

Single Stage - In-Line (left hand actuation shown)

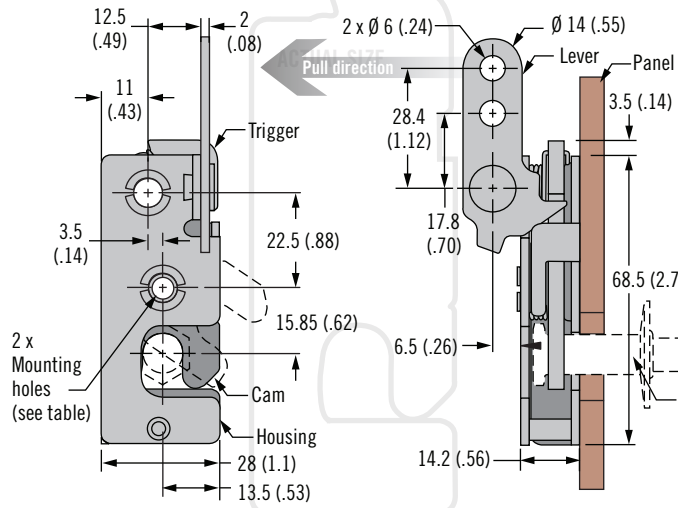

Integrated Bumper Version (dimensions same as standard version except as shown)

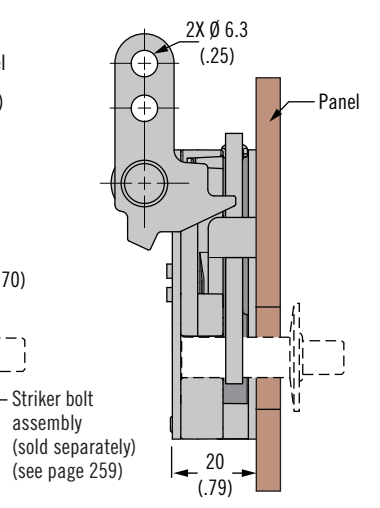

S Stage & Actuation

- 1 Single stage, right hand
- 2 Single stage, left hand
- 3 Two stage, right hand
- 4 Two stage, left hand

L Lever Type

- 1 Perpendicular
- 2 In-Line

I Mounting Style

- 0 $\varnothing 7.2$ (.283) thru
- 1 1/4-20 thread
- 2 M6 x 1 thread

B Base Style

- 1 Standard
- 5 Integrated bumper version

M Material

- 10 Steel
- 20 Stainless steel

R4 - 10 - S I - L O B - M

Other options available. For complete details on variety, part numbers, installation and specification, go to



www.southco.com/R4

Dimensions in millimeters (inch) unless otherwise stated

R4 Rotary Latch

Mini · Concealed · Single and two stage

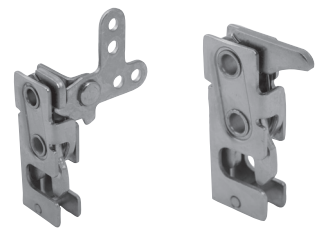

Single Stage - Two Point (left hand actuation shown)

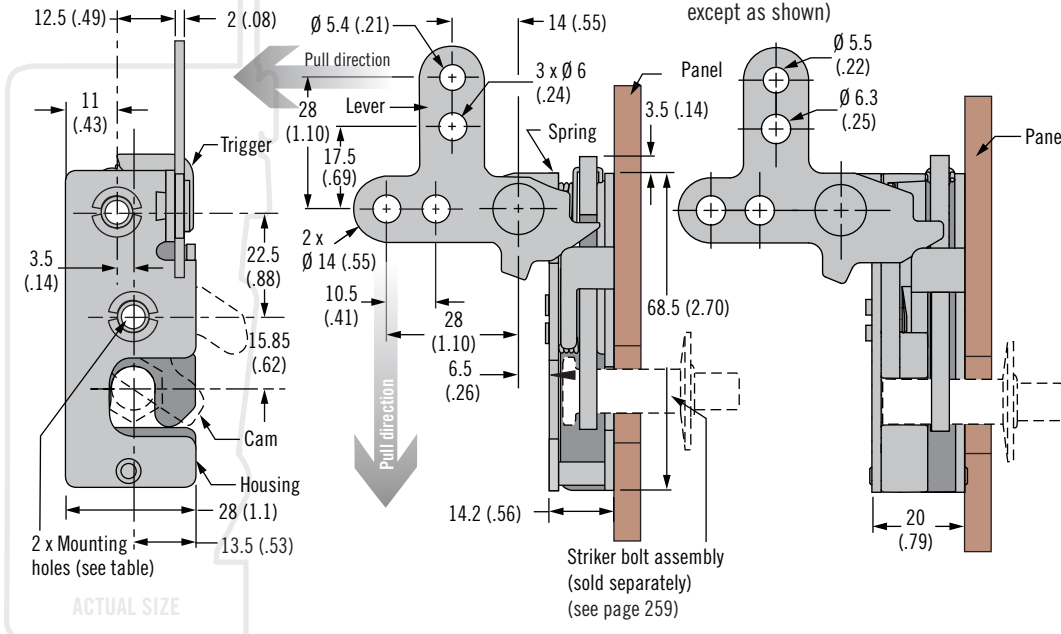

Integrated Bumper Version

(dimensions same as standard version except as shown)

- Single or multi-point latch capability
- Compatible with wide array of actuators
- EN 45545-3 E60 Compliant (Standard version only)
- Integrated bumper version for anti-vibration feature

Material and Finish

Steel, zinc plated or
304 stainless steel, passivated

Performance Details

Average ultimate load
Steel: 4600 N (1100 lbf)
Stainless Steel: 4000 N (900 lbf)

Installation Notes

See page 259

Accessories

Striker bolts for standard version and integrated bumper version are different. See page 259 for both versions.

Cables and retainer clips see page 272-275

Notes

Electromechanical rotary latch available see page 23

Single Stage - Hand Actuation

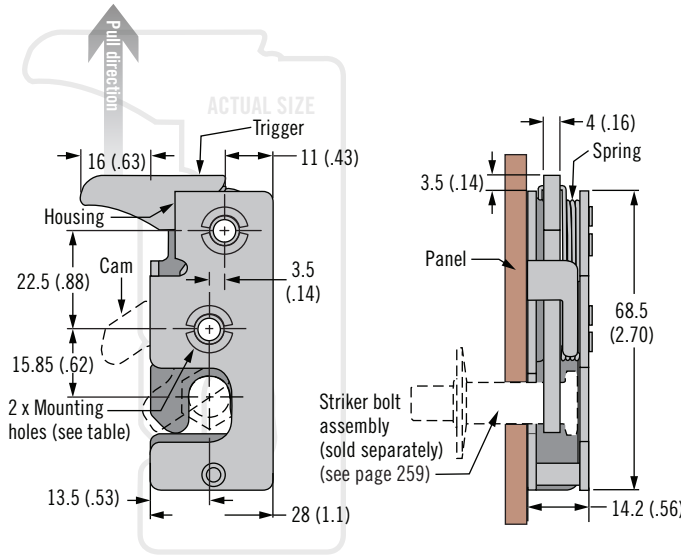

Integrated Bumper Version

(dimensions same as standard version except as shown)

Part Number Selection

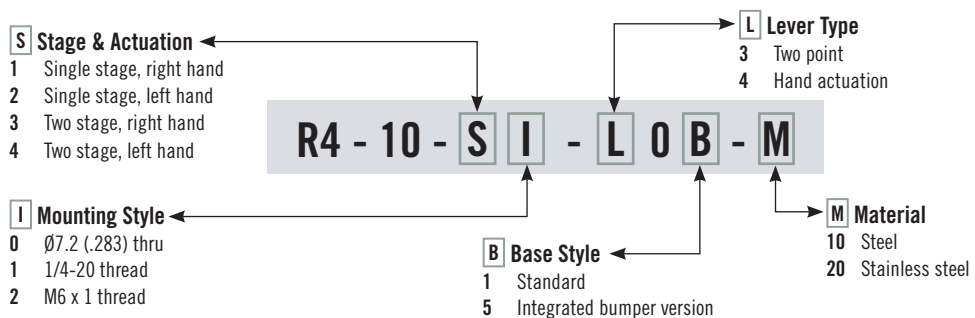



R4 Rotary Latch

Mini · Concealed · Single and two stage

- Single or multi-point latch capability
- Compatible with wide array of actuators
- EN 45545-3 E60 Compliant (Standard version only)
- Integrated bumper version for anti-vibration feature

Material and Finish

Steel, zinc plated or
304 stainless steel, passivated

Performance Details

Average ultimate load
Steel: 4600 N (1100 lbf)
Stainless steel: 4000 N (900 lbf)

Installation Notes

See page 259

Accessories

Striker bolts for standard version and integrated bumper version are different. See page 259 for both versions.

Cables and retainer clips see pages 272-275

Notes

Electromechanical rotary latch available see page 23

Single Stage - Bottom

(left hand actuation shown)

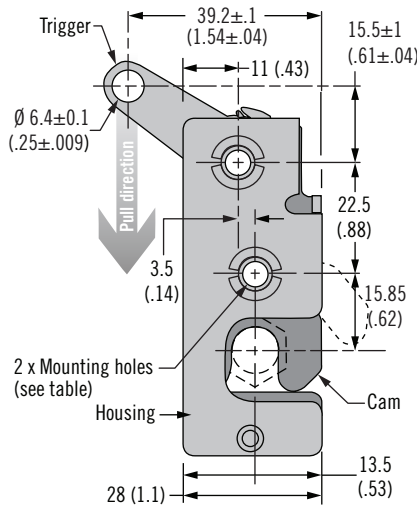

Integrated Bumper Version

(dimensions same as standard version except as shown)

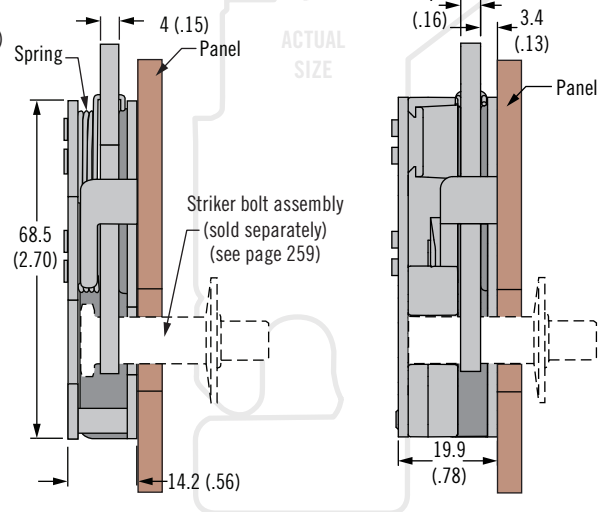

Single Stage - Top

(left hand actuation shown)

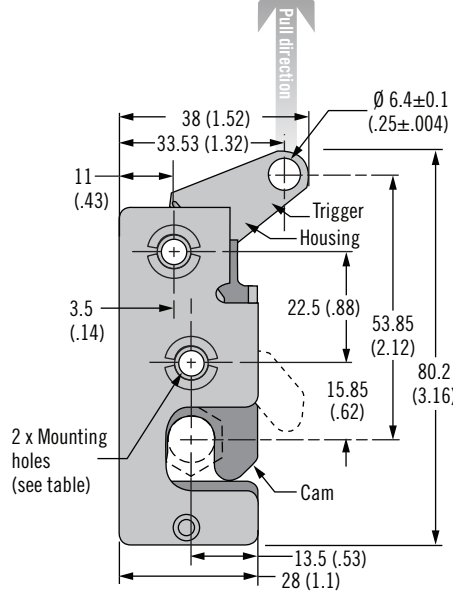

Integrated Bumper Version

(dimensions same as standard version except as shown)

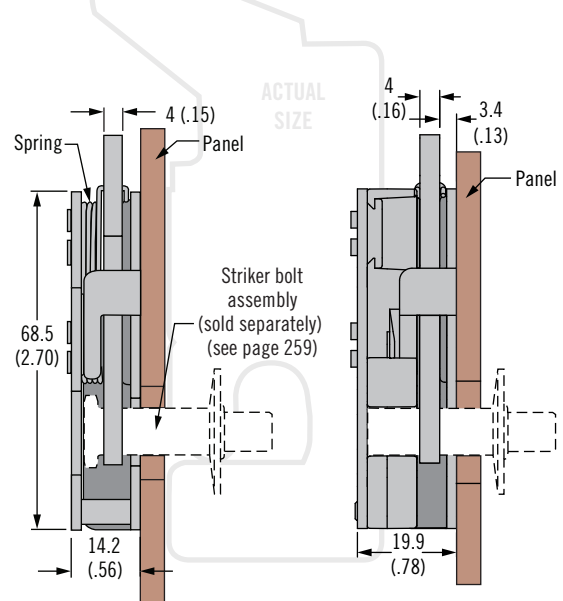

Part Number Selection

S Stage & Actuation
 1 Single stage, right hand
 2 Single stage, left hand
 3 Two stage, right hand
 4 Two stage, left hand

L Lever Type
 5 Bottom
 6 Top

I Mounting Style
 0 Ø7.2 (.283) thru
 1 1/4-20 thread
 2 M6 x 1 thread

B Base Style
 1 Standard
 5 Integrated bumper version

M Material
 10 Steel
 20 Stainless steel

R4 - 10 - S I - L 0 B - M

Other options available. For complete details on variety, part numbers, installation and specification, go to



www.southco.com/R4

Dimensions in millimeters (inch) unless otherwise stated



R4 Rotary Latch

Mini · Concealed · Dual Trigger · Single and two stage

Single Stage - Dual Trigger - Bottom

(left hand actuation shown)

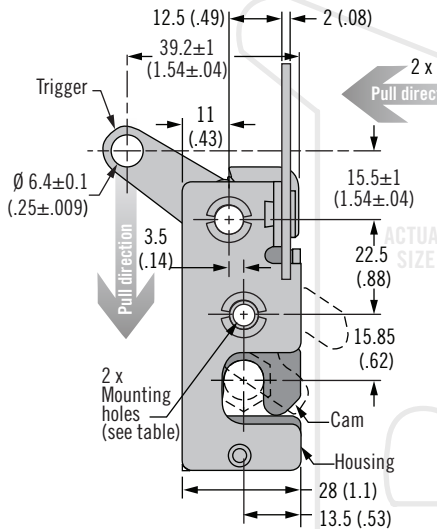

Integrated Bumper Version

(dimensions same as standard version except as shown)

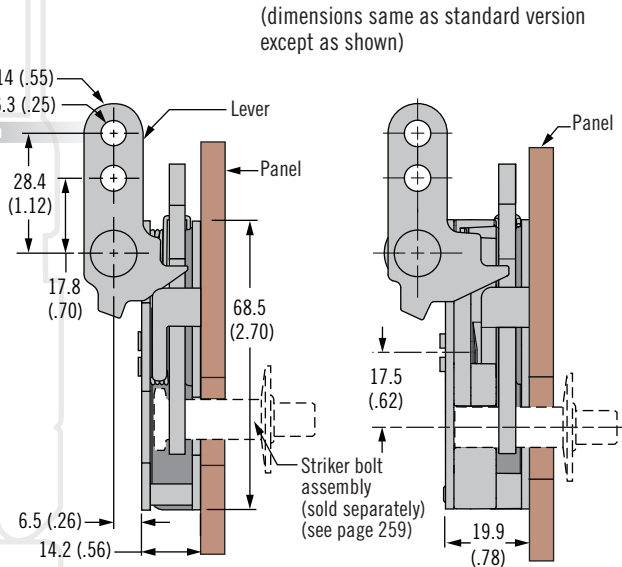

Single Stage - Dual Trigger - Top

(left hand actuation shown)

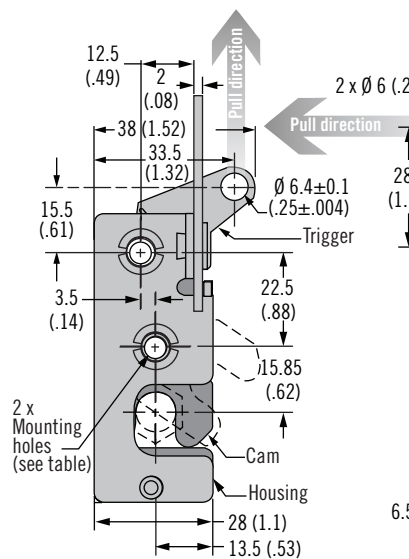

Integrated Bumper Version

(dimensions same as standard version except as shown)

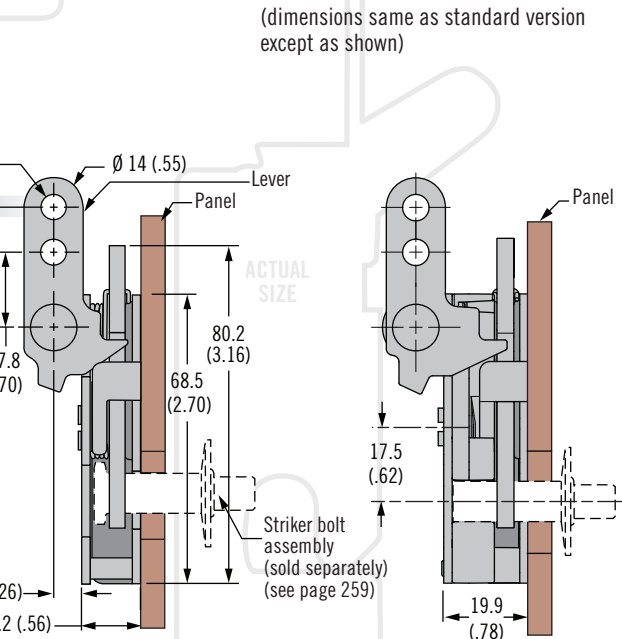

- Single or multi-point latch capability
- Compatible with wide array of actuators
- EN 45545-3 E60 Compliant (Standard version only)
- Integrated bumper version for anti-vibration feature

Material and Finish

Steel, zinc plated

Performance Details

Average ultimate load
Steel: 4500 N (1000 lbf)

Installation Notes

See page 259

Accessories

Striker bolts for standard version and integrated bumper version are different. See page 259 for both versions.

Cables and retainer clips
see page 272-275

Trigger - use retaining clip
R4-0-43922-2

Lever - use retaining clip
R4-0-43922

Notes

Electromechanical rotary latch
available see page 23

Part Number Selection

<p>S Stage & Actuation</p> <ul style="list-style-type: none"> 1 Single stage, right hand 2 Single stage, left hand 3 Two stage, right hand 4 Two stage, left hand 	<p>L Lever Type</p> <ul style="list-style-type: none"> 7 Dual Trigger, Bottom 8 Dual Trigger, Top
--	--

R4 - 10 - S I - L 0 B - M

<p>I Mounting Style</p> <ul style="list-style-type: none"> 0 Ø7.2 (.283) thru 1 1/4-20 thread 2 M6 x 1 thread 	<p>B Base Style</p> <ul style="list-style-type: none"> 1 Standard 5 Integrated bumper version 	<p>M Material</p> <ul style="list-style-type: none"> 10 Steel
---	--	---





R4 Rotary Latch

Mini · Concealed · Single and two stage

- Direct actuation, no cable or rod required
- Integrated bumper version for anti-vibration feature
- EN 45545-3 E60 Compliant (Standard version only)

Material and Finish

Steel, zinc plated or 304 stainless steel, passivated

Performance Details

Average ultimate load
 Steel: 4500 N (1010 lbf)
 Stainless steel: 4000 N (900 lbf)

Installation Notes

See page 259

Accessories

Striker bolts for standard version and integrated bumper version are different. See page 259 for both versions.

Notes

Electromechanical rotary latch available see page 23

Part Number Selection

Single Stage - Top

(left hand actuation shown)

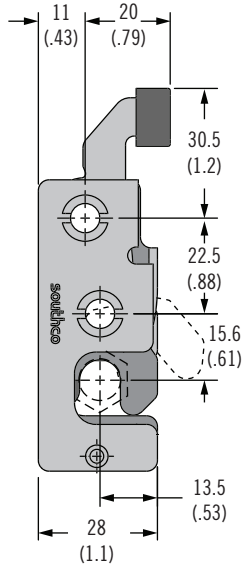

Integrated Bumper Version

(dimensions same as standard version except as shown)

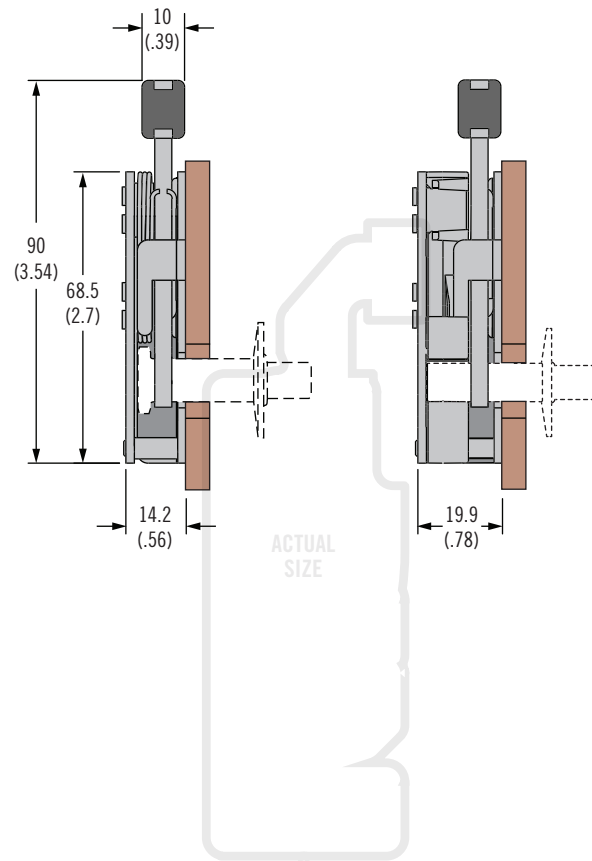

S Stage & Actuation

- 1 Single stage, right hand
- 2 Single stage, left hand
- 3 Two stage, right hand
- 4 Two stage, left hand

I Mounting Style

- 0 $\varnothing 7.2$ (.283) thru
- 1 1/4-20 thread
- 2 M6 x 1 thread

B Base Style

- 1 Standard
- 5 Integrated bumper version

M Material

- 10 Steel
- 20 Stainless steel

R4 - 10 - S I - 90 B - M





R4 Rotary Latch

Integrated Cable Mounting Bracket · Stainless Steel
Mini · Concealed · Single stage

Single Stage - Bottom

(left hand actuation shown)

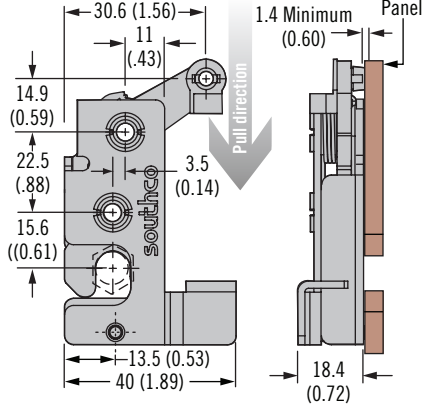

Integrated Bumper Version

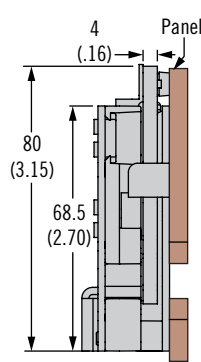

Panel Preparation

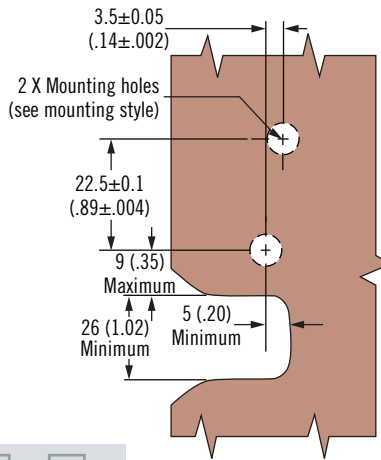

R4 - 10 - S I - 50 B - M

S Stage & Actuation

- 1 Single stage, right hand
- 2 Single stage, left hand

I Mounting Style

- 0 $\varnothing 7.2$ (.283) thru
- 1 1/4-20 thread
- 2 M6 x 1 thread

B Base Style

- 2 Standard
- 6 Integrated bumper version

M Material

- 10 Steel
- 20 Stainless steel

Material and Finish

304 stainless steel

Performance Details

Average ultimate load:
4000 N (900 lbf)

Accessories

- Striker bolt
- Cables and retainer clips

R4 Rotary Latch

Striker bolt · Mini · Installation

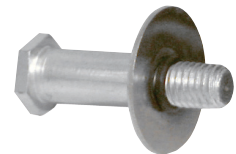

Striker Bolt Assembly - Standard

(sold separately)

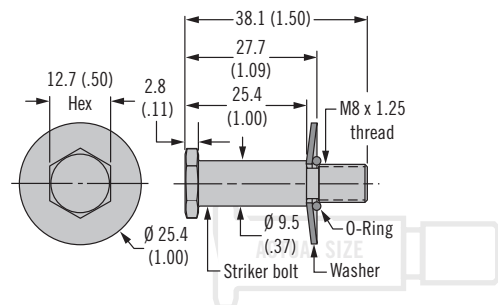

Striker Bolt Assembly - Integrated Bumper

(sold separately)

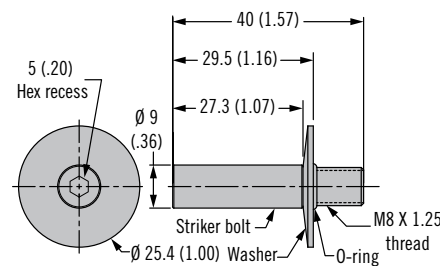

Striker 90° Mounting Bracket

Striker Mounting Bracket Part Number

R4-0-50114

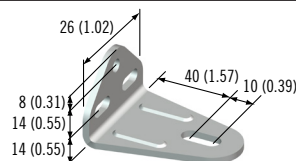

Striker Bolt Part Number - Standard	
Part Number	Material
R4-90-121-10	Steel
R4-90-121-20	Stainless Steel
Striker Bolt Part Number - Integrated Bumper Version	
R4-90-124-10	Steel
R4-90-124-20	Stainless Steel

- Striker bolt for R4-10 series rotary latch

Material and Finish

Steel, zinc plated or stainless steel

Operation

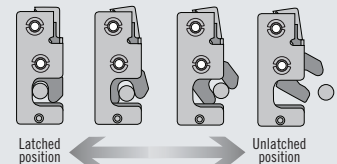

Part Number

See table

Other options available. For complete details on variety, part numbers, installation and specification, go to



www.southco.com/R4



R4 Rotary Latch

Large · Concealed · Two stage

- Single or multi-point latch capability
- Compatible with wide array of actuators
- FMVSS 206 compliant
- EN 45545-3 E60 Compliant

Material and Finish

Steel, zinc plated or stainless steel

Performance Details

Average ultimate load:
 10675 N (2400 lbf) as shown
 14230 N (3200 lbf) with
 support bracket. Contact Southco
 for more information

Installation Notes

See page 261

Accessories

Striker bolt see page 261

Cables and retainer clips
 see pages 272-275

Notes

Electromechanical rotary latch
 available see page 23

Two Stage - Perpendicular (left hand actuation shown)

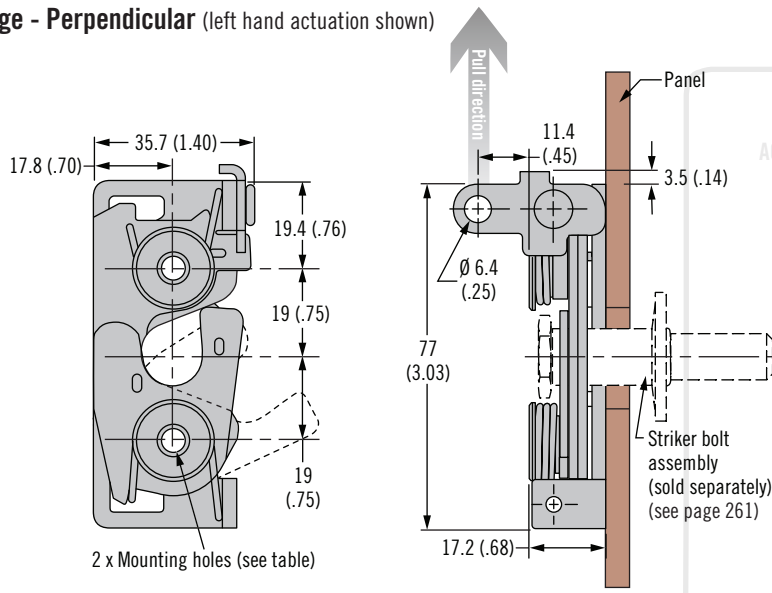

Two Stage - Bottom (left hand actuation shown)

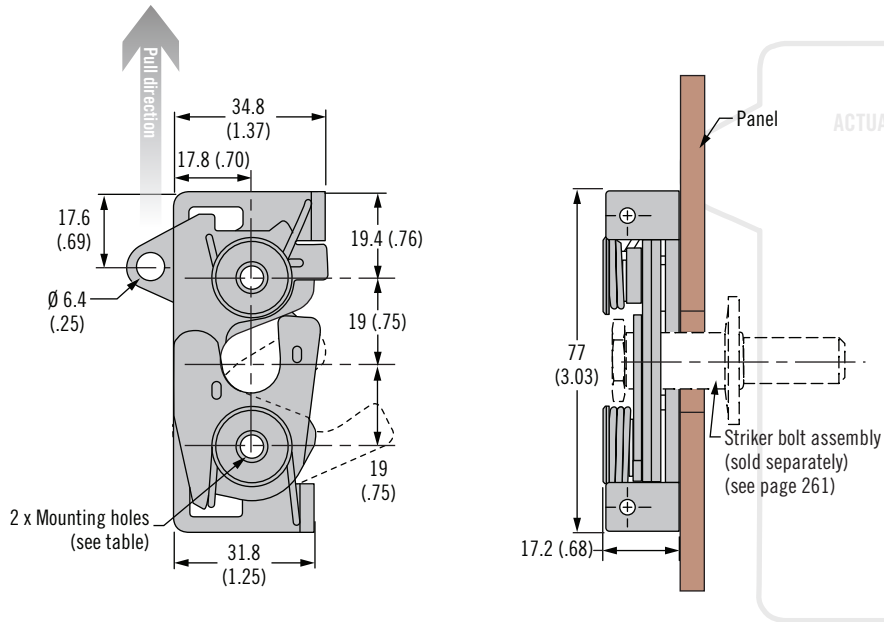

Part Number Selection

S Stage & Actuation
 3 Two stage, right hand
 4 Two stage, left hand

L Lever Type
 1 Perpendicular
 3 Two point
 5 Bottom

I Mounting Style
 0 Ø7.2 (.283) thru
 1 1/4-20 thread
 2 M6 x 1 thread

M Material
 10 Steel
 20 Stainless steel

R4 - 30 - S I - L 0 1 - M

Other options available. For complete details on variety, part numbers, installation and specification, go to



www.southco.com/R4

Dimensions in millimeters (inch) unless otherwise stated

R4 Rotary Latch

Large · Concealed · Two stage



2-Point Actuator (left hand actuation shown)

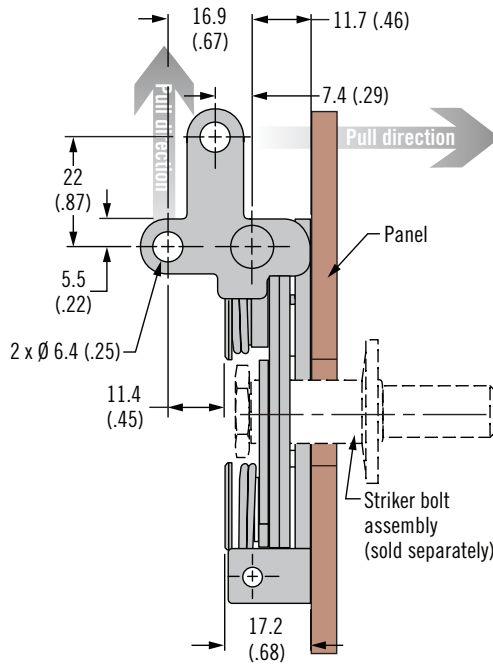
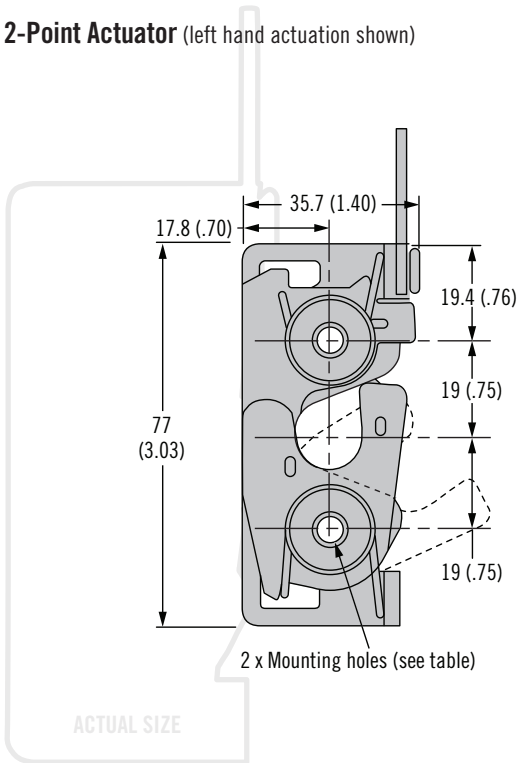

Striker Bolt Assembly (sold separately)

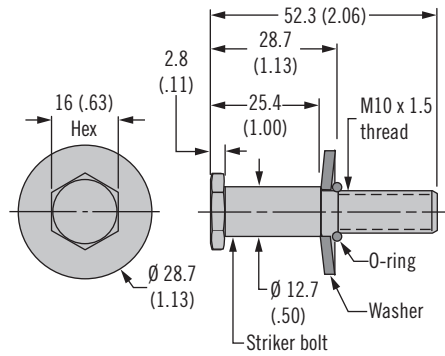
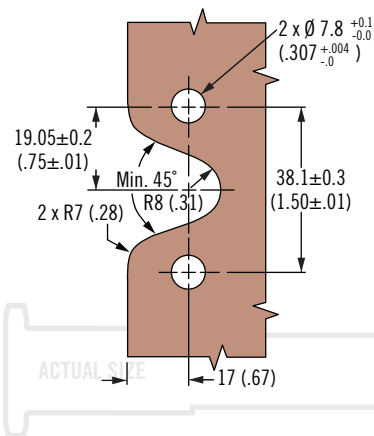

Striker Bolt Assembly Part Number

See table

Striker Bolt Part Number	
Part Number	Material
R4-90-321-10	Steel
R4-90-321-20	Stainless Steel

Operation

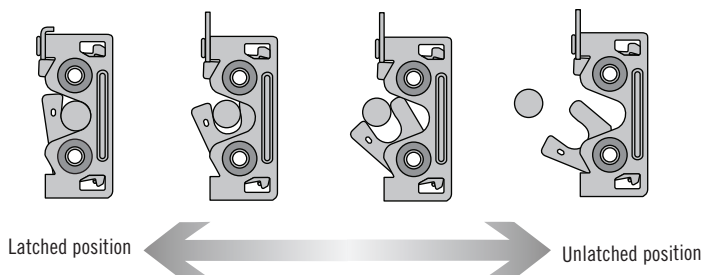



R4 Rotary Latch

Medium · Concealed · Single and two stage

- Single or multi-point latch capability
- Compatible with wide array of Actuators
- EN 45545-3 E60 Compliant

Material and Finish

Steel, zinc plated

Accessories

Cables and retainer clips see pages 272-275

Notes

Electromechanical rotary latch available see page 23

For panel preparation visit www.southco.com/R4

Single Stage (left hand actuation shown)

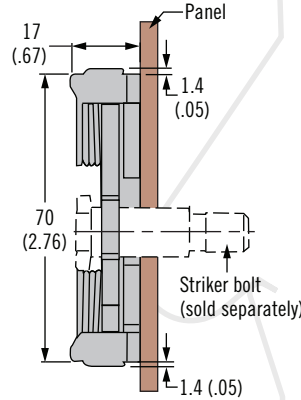
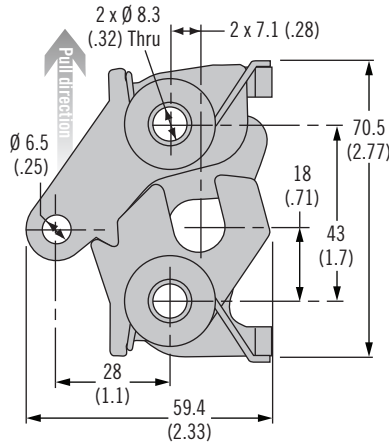

ACTUAL SIZE

Two Stage (left hand actuation shown)

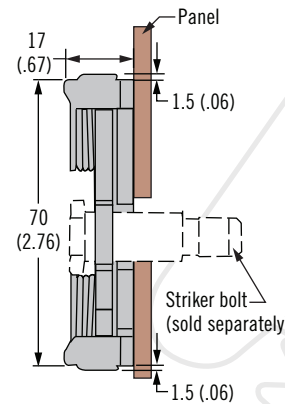
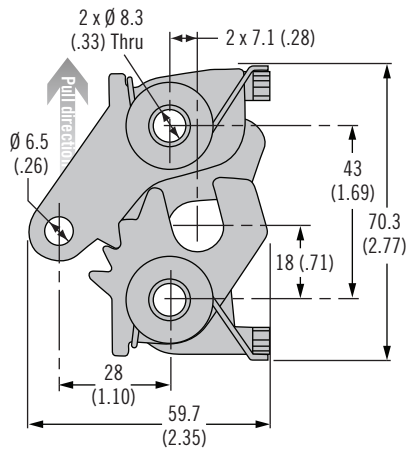

Striker Bolt (sold separately)

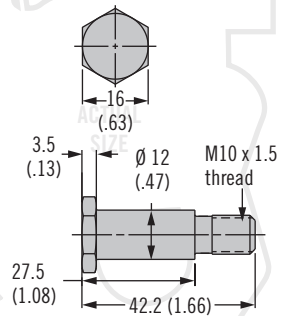

Operation

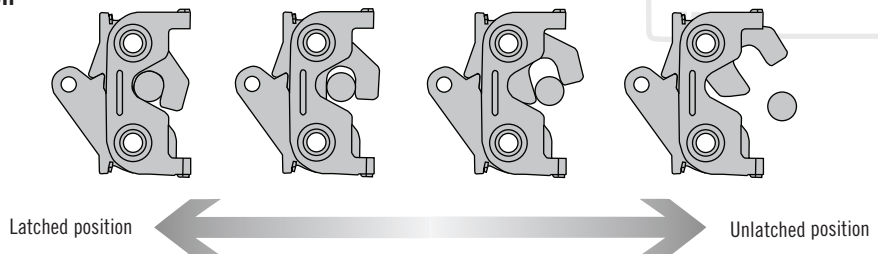

Part Number

See table

Order latch and striker separately

Position	Part Number		
	Left Hand Actuation	Right Hand Actuation	Striker Bolt
Single stage	R4-20-20-501-10	R4-20-10-501-10	R4-91-231-10
Two stage	R4-20-40-501-10	R4-20-30-501-10	

Other options available. For complete details on variety, part numbers, installation and specification, go to



Dimensions in millimeters (inch) unless otherwise stated

R4 Rotary Latch

Heavy-duty · Two stage



Two Stage (left hand actuation shown)

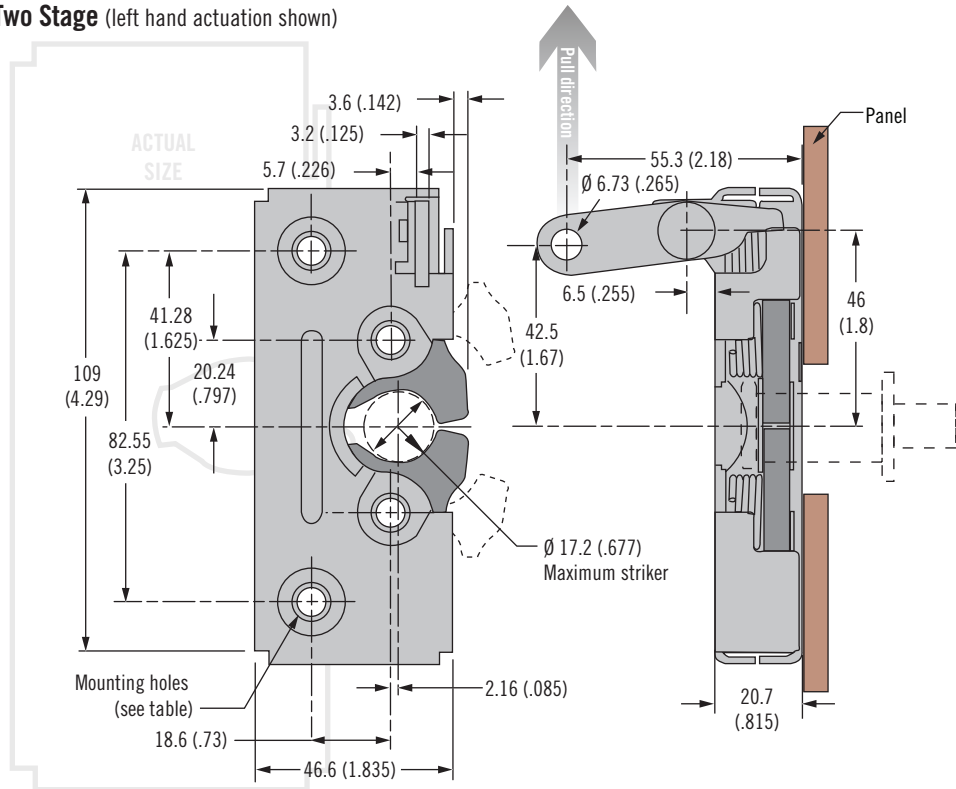

- Single or multi-point latch capability
- Compatible with wide array of actuators
- FMVSS 206 compliant
- EN 45545-3 E60 Compliant

Material and Finish

Steel, zinc plated

Accessories

Cables and retainer clips
see pages 272-275

Notes

Electromechanical rotary latch available see page 23

For panel preparation visit
www.southco.com/R4

Striker Bolt Assembly (sold separately)

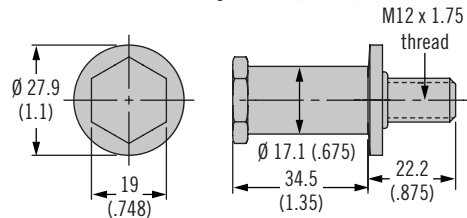

Operation

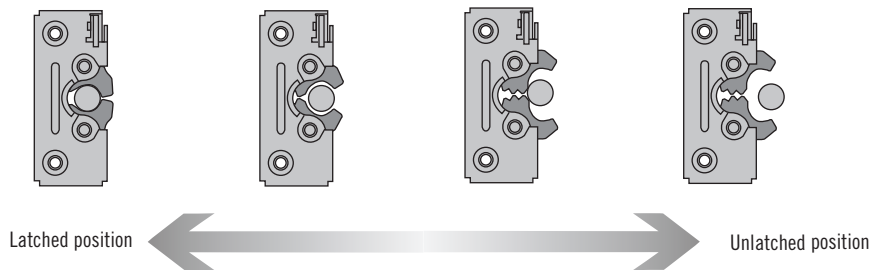

Mounting Style	Part Number		
	Left Hand Actuation	Right Hand Actuation	Striker Bolt
$\varnothing 7.2$ (.283) Thru	R4-50-40-101-10	R4-50-30-101-10	R4-90-441-10
1/4-20 Thread	R4-50-41-101-10	R4-50-31-101-10	
M6 X 1 Thread	R4-50-42-101-10	R4-50-32-101-10	

Part Number

See table

Order latch and striker bolt separately

Other options available. For complete details on variety, part numbers, installation and specification, go to



www.southco.com/R4